

QPD2-0-50000-1-2

DC~50GHz, 1W

Features:
 * Small Size
 * Low Insertion Loss

Applications:
 * Amplifiers
 * Mixers
 * Antennas
 * Laboratory Test

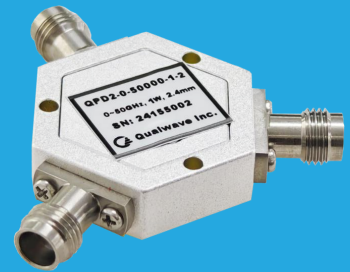

Electrical

Frequency:	DC~50GHz
Insertion Loss ^{*1} :	2.2dB max.
VSWR:	1.5 max.
Isolation:	6dB typ.
Amplitude Balance:	±0.5dB
Phase Balance:	±9°
Impedance:	50Ω
Power @SUM Port:	1W as divider

[1] Excluding theoretical loss 6.0dB.

Mechanical

Size ^{*2} :	25.98*29.69*8mm 1.023*1.169*0.315in
Connectors:	2.4mm Female
Mounting:	3-Φ2.2mm through-hole

[2] Exclude connectors.

Environmental

Operation Temperature:	-35~+75°C
------------------------	-----------

Outline Drawings

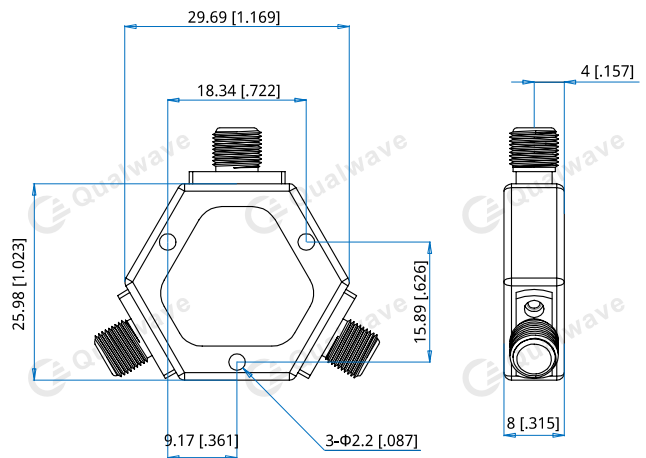

Unit: mm [in]
 Tolerance: ±0.5mm [±0.02in]

How To Order

QPD2-0-50000-1-2

Customization is available upon request.