

QBF-50-150-45

0.05~0.15GHz, 45dB

Features:

- * High Stopband Rejection
- * Small Size

Applications:

- * Telecom
- * Laboratory Test
- * Receivers
- * Instrumentation

Electrical

Passband:	0.05~0.15GHz
Passband Insertion Loss:	1.0dB max.
Passband Ripple:	0.6dB max.
VSWR:	1.45 max.
Stopband Attenuation:	45dB @ DC ~ 35MHz min. 45dB @ 210 ~ 1000MHz min.
Impedance:	50Ω
Average Power:	1W max.

Mechanical

Size ^{*1} :	40*18*13mm 1.575*0.709*0.512in
Weight:	0.025Kg
Connectors:	SMA Female
Mounting:	4-M2 through hole

[1] Exclude connectors.

Environmental

Temperature:	-30~+70°C
--------------	-----------

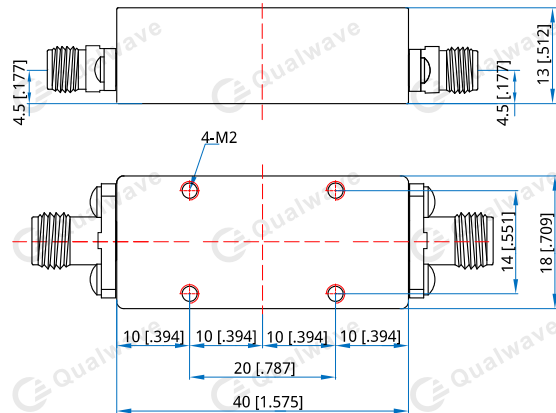
Outline Drawings

Unit: mm [in]

Tolerance: ±0.2mm [±0.008in]

How To Order

QBF-50-150-45

Customization is available upon request.