

QADD SMB to SMB

Features:
* Low VSWR

Applications:
* Wireless
* Transmitter
* Laboratory Test
* Radar



Electrical

Frequency:	DC~4GHz DC~6GHz (Outline D)
VSWR:	1.15 max. 1.2 max.(Outline D)
Impedance:	50Ω

Mechanical

RF Connectors:	SMB
Mating Life Cycle:	500 cycles
Outer Conductor:	Gold Plated Brass Passivated Stainless Steel (Outline D)
Dielectric:	PTFE
Inner Conductor:	Gold Plated Beryllium Copper

Environmental

Temperature:	-55~+165°C
--------------	------------

Outline Drawings

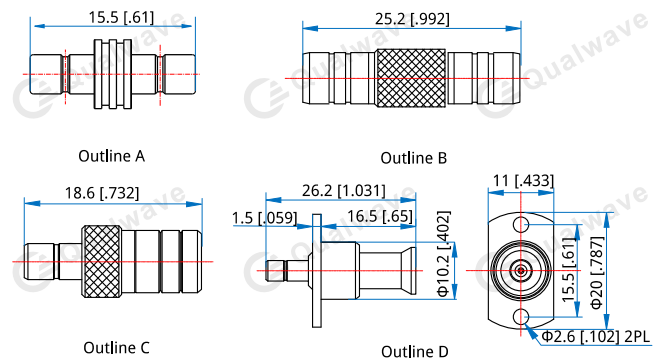

Unit: mm [in]
Tolerance: ±0.2mm [±0.008in]

How To Order

- QADD-MM** - SMB(m) to SMB(m), Outline A
- QADD-FF** - SMB(f) to SMB(f), Outline B
- QADD-MF** - SMB(m) to SMB(f), Outline c
- QADDL-MF** - SMB(m) to SMB(f), Flange mount, Outline D

Customization is available upon request.