

QDI4027X

High Power, High Isolation

Features:
 * High Power
 * High Isolation
 * Low Insertion Loss
 * Low VSWR

Applications:
 * Wireless
 * Radar
 * Laboratory Test

Description

QDI4027X series Drop-In Isolators cover frequency range 600~2700MHz. High power, high isolation and low insertion loss make it ideal for a lot of applications like amplifiers, transceivers, etc.

Specifications

Frequency (MHz)	Bandwidth (MHz)	Insertion Loss (dB Max.)	Isolation (dB Min.)	VSWR (Max.)	Fwd Power (W Max.)	Rev Power (W)	Temperature (°C)
870~880	10	0.50	60.0	1.20	100	10~100	-30~+70
930~960	60	0.50	60.0	1.20	100	10~100	-30~+70
1805~1880	75	0.50	55.0	1.20	100	10~100	-30~+70
2010~2025	15	0.50	60.0	1.20	100	10~100	-30~+70
2110~2170	60	0.60	50.0	1.20	100	10~100	-30~+70
2300~2700	400	0.80	40.0	1.20	100	10~100	-30~+70
2400~2500	100	0.50	50.0	1.20	100	10~100	-30~+70
2500~2600	100	0.50	50.0	1.20	100	10~100	-30~+70
2600~2700	100	0.50	50.0	1.20	100	10~100	-30~+70

Outline Drawings

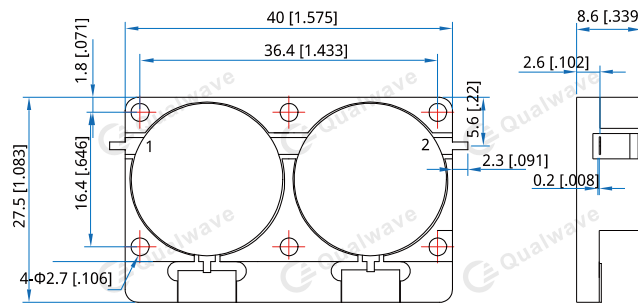

Unit: mm [inch] Tolerance: ±0.2mm [±0.008in]

Mechanical

Size*1: 40*27.5*8.6mm
 1.575*1.083*0.339in
 Connector Type: Strip line
 Mounting: 4-Φ2.7mm through-hole

[1] Exclude connectors and terminations.

How To Order

QDI4027X-V-W-X-Y-Z
 V: Start frequency in MHz
 W: Stop frequency in MHz
 X: Forward Power in W
 Y: Reverse Power in W
 Z: Direction type

Direction Naming Rules:

1 - Clockwise
 2 - Anticlockwise

Examples:

To order a QDI4027X series Isolator, 930~960MHz, Forward power 100W, Reverse power 10W, Clockwise, specify QDI4027X-930-960-K1-10-1.

Customization is available upon request.