

QHF-5480-18000-50

5.48~18GHz, 50dB

Features:

- * High Stopband Rejection
- * Small Size

Applications:

- * Telecom
- * Laboratory Test
- * Receivers
- * Instrumentation

Electrical

| | |
|--------------------------|---------------------|
| Passband: | 5.48~18GHz |
| Passband Insertion Loss: | 0.9dB max. |
| VSWR: | 2 max. |
| Stopband Attenuation: | 50dB@DC~3.5GHz min. |
| Power: | 10W max. |

Mechanical

| | |
|----------------|-------------------|
| RF Connectors: | SMA Female |
| Mounting: | 4-M2 through-hole |

Environmental

| | |
|----------------------------|-----------|
| Operating Temperature: | -40~+70°C |
| Non-operating Temperature: | -55~+85°C |

How To Order

QHF-5480-18000-50

Customization is available upon request.

Outline Drawings

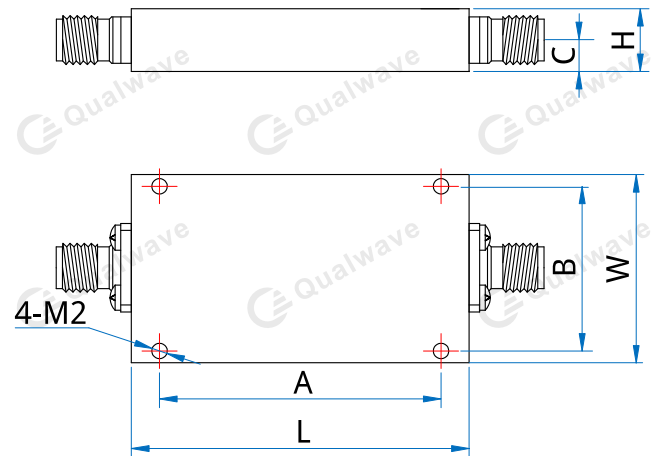

| Size | L | W | H | A | B | C |
|------|------|-------|-------|-------|-------|-------|
| mm | 31 | 24 | 11 | 27 | 20 | 5.5 |
| in | 1.22 | 0.945 | 0.433 | 1.063 | 0.787 | 0.217 |

Unit: mm [in]

Tolerance: $\pm 0.2\text{mm}$ [$\pm 0.008\text{in}$]