

QLAS-10-60-16-50

10~60MHz, 16dB, 5dB

Features:
 * Broad Band
 * Low Noise

Applications:
 * Wireless
 * Receiver
 * Laboratory Test
 * Radar

Electrical

Frequency:	10~60MHz
Gain:	16dB min.
Gain Flatness:	±1.5dB
Output Power (P1dB):	23dBm
Noise Figure:	5dB max.
Spurious:	-60dBc max.
Voltage:	+220V AC

Mechanical

Size*1: 136*186*52mm
 5.354*7.323*2.047in

RF Connectors: SMA Female

[1] Exclude connectors, rack mount brackets, handles.

How To Order

QLAS-10-60-16-50

Customization is available upon request.

Environmental

Operating Temperature:	-20~+60°C
Non-operating Temperature:	-40~+85°C

Outline Drawings

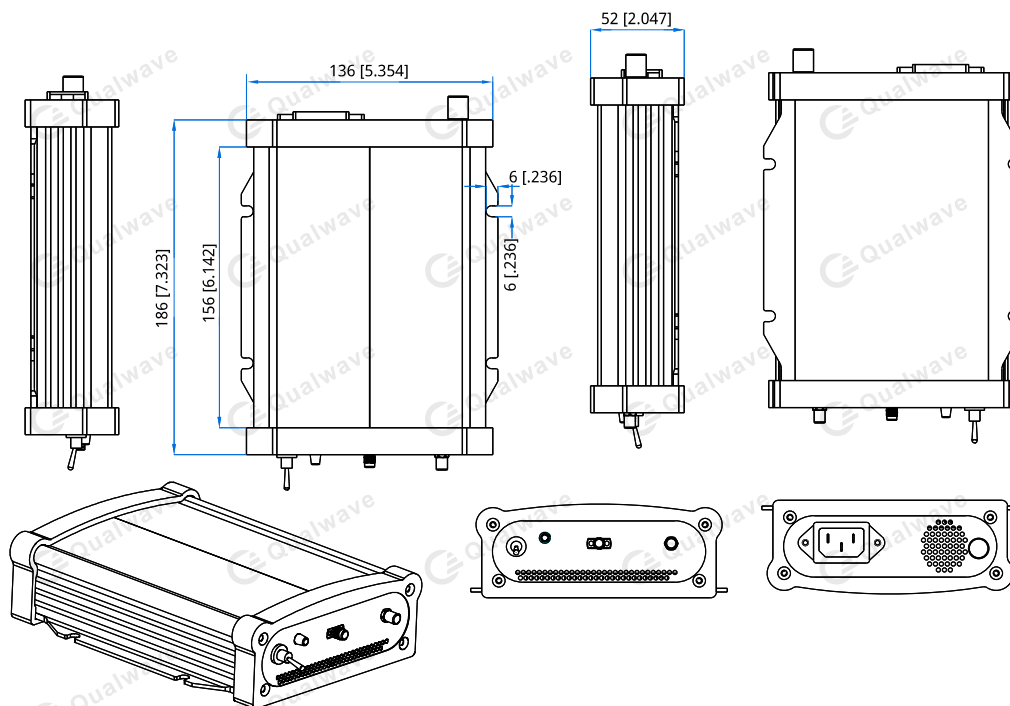

Unit: mm [in]

Tolerance: ±0.2mm [±0.008in]