

QLAS-1000-40000-40-50

1~40GHz, 40dB, 5dB

Features:
 * Broad Band
 * Low Noise

Applications:
 * Wireless
 * Receiver
 * Laboratory Test
 * Radar

Electrical

Frequency:	1~40GHz
Gain:	40dB min. 45dB typ.
Gain Flatness:	±4.5dB typ.
Output Power (Psat):	+16dBm typ.
Noise Figure:	5dB typ.
Spurious:	-60dBc max.
Harmonic:	-15dBc typ.
VSWR:	2.5 typ. 3 max.
Voltage:	+220V AC
Impedance:	50Ω

Environmental

Operating Temperature:	-20~+50°C
Non-operating Temperature:	-40~+85°C

Mechanical

Size*1: 136*186*52mm
 5.354*7.323*2.047in

RF Connectors: 2.92mm Female

[1] Exclude connectors, rack mount brackets, handles.

How To Order

QLAS-1000-40000-40-50

Customization is available upon request.

Outline Drawings

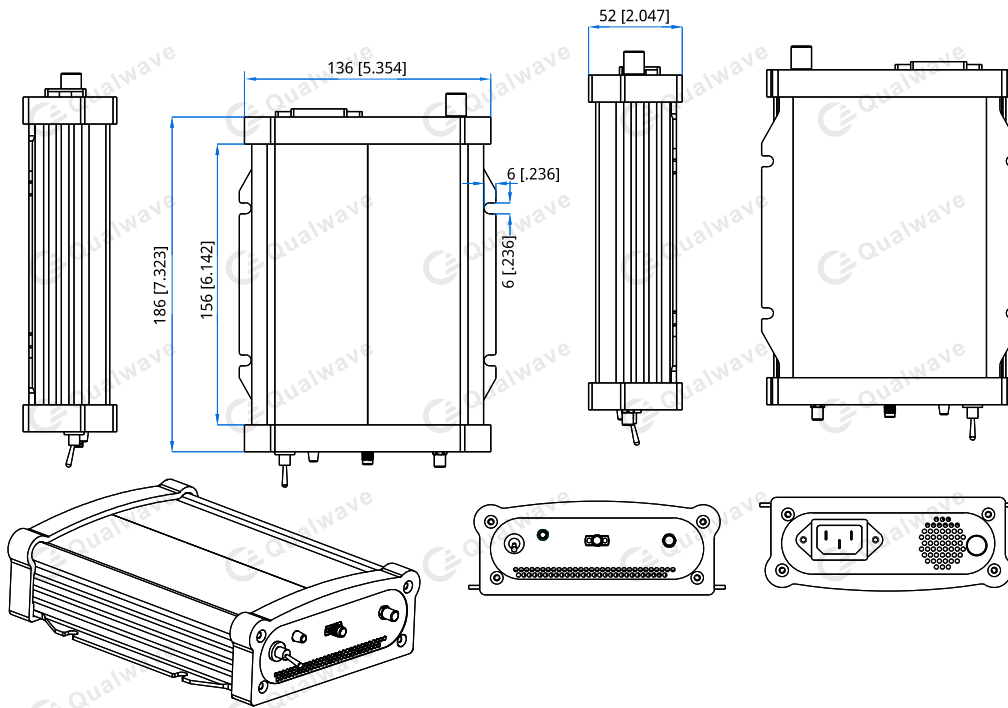

Unit: mm [in]

Tolerance: ±0.2mm [±0.008in]