

QLAS-18000-28000-28-30

18~28GHz, 28dB, 3dB

Features:
 * Broad Band
 * Low Noise

Applications:
 * Wireless
 * Receiver
 * Laboratory Test
 * Radar

Electrical

Frequency:	18~28GHz
Gain:	28dB min.
Gain Flatness:	±1.5dB typ.
Output Power (P1dB):	+5dBm typ.
Noise Figure:	3dB typ.
VSWR:	1.8 typ.
Voltage:	+220V AC
Impedance:	50Ω
Input Power:	+10dBm max.

Mechanical

Size*1: 136*186*52mm
 5.354*7.323*2.047in

RF Connectors: 2.92mm Female

[1] Exclude connectors, rack mount brackets, handles.

How To Order

QLAS-18000-28000-28-30

Customization is available upon request.

Environmental

Operating Temperature: -40~+60°C
 Non-operating Temperature: -40~+85°C

Outline Drawings

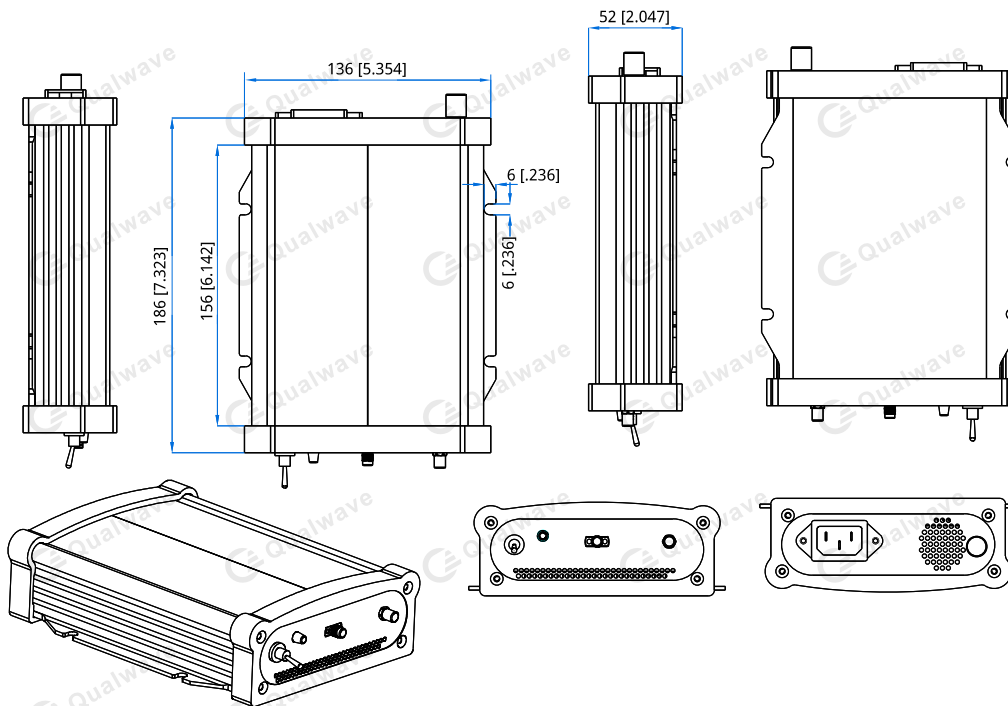

Unit: mm [in]

Tolerance: ±0.2mm [±0.008in]