

# QLAS-700-8000-30-25

0.7~8GHz, 30dB, 2.5dB

Features:  
 \* Broad Band  
 \* Low Noise

Applications:  
 \* Wireless  
 \* Receiver  
 \* Laboratory Test  
 \* Radar

### Electrical

Frequency:	0.7~8GHz
Gain:	30dB min.
Passband Ripple:	±2dBm typ.
Noise Figure:	2.5dB typ.
Output Power (P1dB):	13dBm typ.
Spurious:	-60dBc max.
Harmonic:	-20dBc max.
IP3:	23dB typ.
Input VSWR:	2 typ.
Output VSWR:	2 typ.
Voltage:	220V AC
Current:	200mA typ.
Input Power Without Damage:	+10dBm max.

### Environmental

Operating Temperature:	-20~+65°C
Non-operating Temperature:	-30~+70°C

### Mechanical

Size*1:	136*186*52mm
	5.354*7.323*2.047in

RF Connectors: SMA Female

[1] Exclude connectors, rack mount brackets, handles.

### How To Order

**QLAS-700-8000-30-25**

Customization is available upon request.

### Outline Drawings

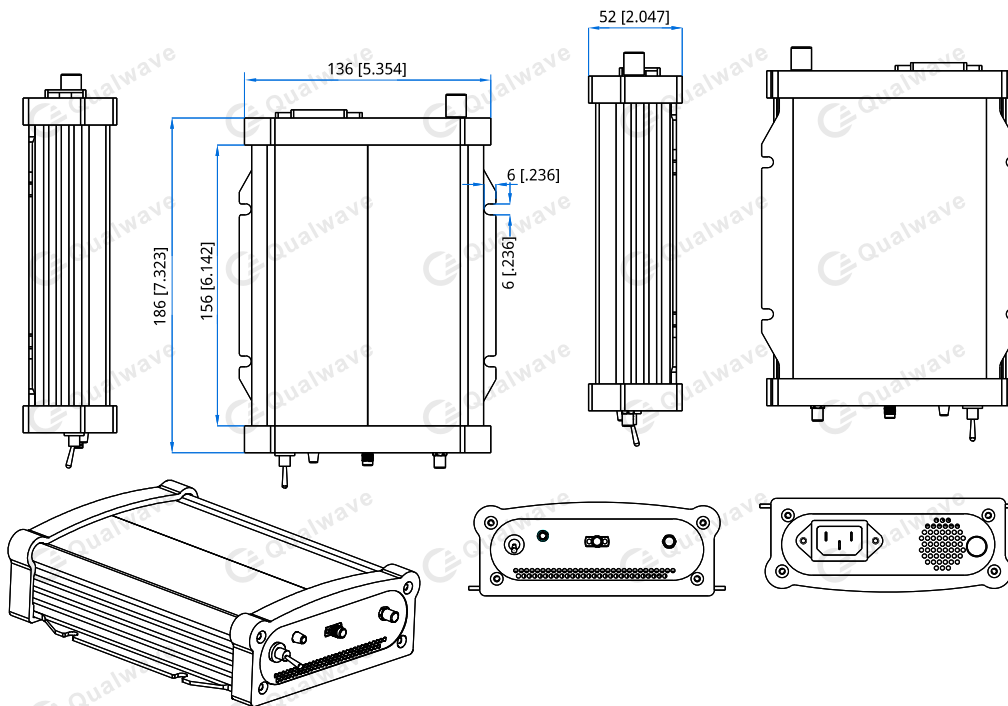

Unit: mm [in]  
 Tolerance: ±0.2mm [±0.008in]