

# QLAS-8000-12000-15-40

8~12GHz, 15dB, 4dB

Features:  
 \* Broad Band  
 \* Low Noise

Applications:  
 \* Wireless  
 \* Receiver  
 \* Laboratory Test  
 \* Radar

## Electrical

Frequency:	8~12GHz
Gain:	15dB min.
Gain Flatness:	±0.5dB typ.
Output Power (P1dB):	+13dBm min.
Noise Figure:	4dB max.
Spurious:	-60dBc max.
VSWR:	1.5 typ.
Voltage:	+220V AC
Impedance:	50Ω

## Mechanical

Size\*1: 136\*186\*52mm  
 5.354\*7.323\*2.047in

RF Connectors: SMA Female

[1] Exclude connectors, rack mount brackets, handles.

## How To Order

**QLAS-8000-12000-15-40**

Customization is available upon request.

## Environmental

Operating Temperature: -20~+50°C  
 Non-operating Temperature: -40~+85°C

## Outline Drawings

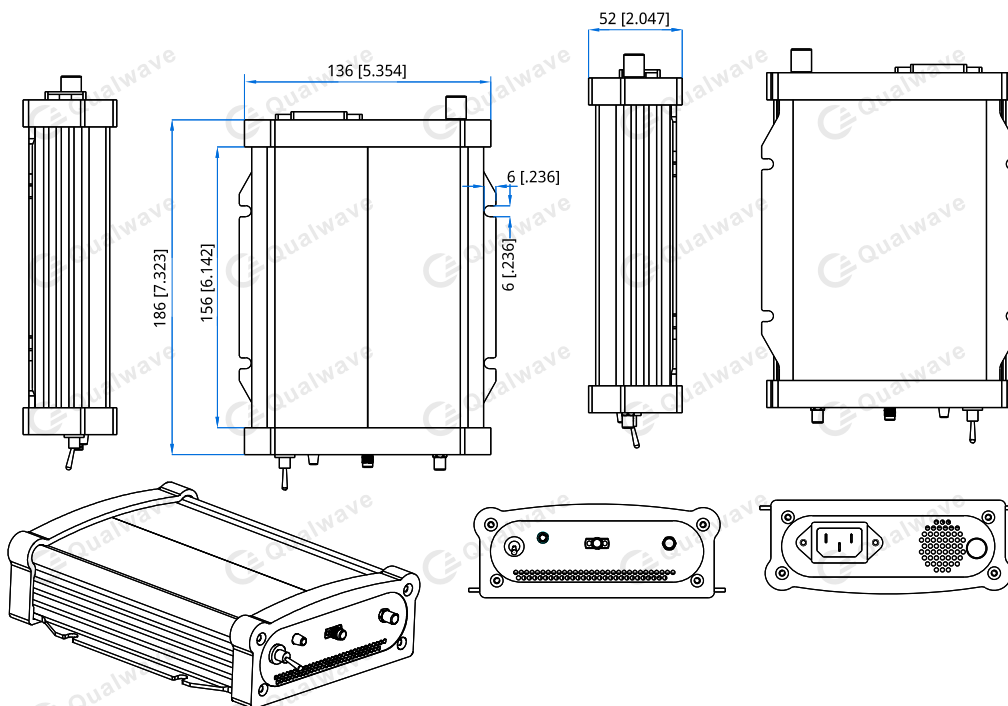

Unit: mm [in]

Tolerance: ±0.2mm [±0.008in]