

QLA-1000-18000-47-25

1~18GHz, 47dB, 2.5dB

Features:
 * Broad Band
 * Low Noise

Applications:
 * Wireless
 * Receiver
 * Laboratory Test
 * Radar

Electrical

Frequency:	1~18GHz
Gain:	47dB min. 50dB typ.
Gain Flatness:	±1.5dB typ.
Output Power (P1dB):	+10dBm min.
Noise Figure:	2.5dB max.
VSWR:	2 max.
Voltage:	+9V DC
Current:	150mA typ.
Impedance:	50Ω

Mechanical

Size ^{*1} :	21.8*17.8*7.4mm 0.858*0.701*0.291in
RF Connectors:	SMA Female

[1] Exclude connectors.

Environmental

Operating Temperature:	-40~+70°C
Non-operating Temperature:	-55~+85°C

Outline Drawings

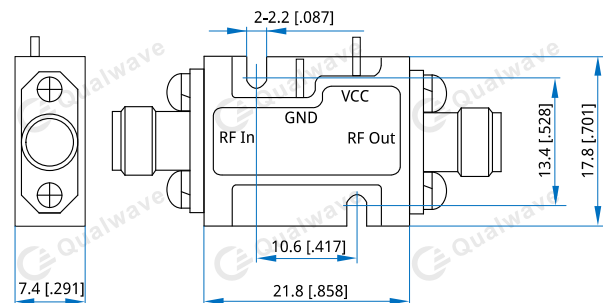

Unit: mm [in]

Tolerance: ±0.2mm [±0.008in]

How To Order

QLA-1000-18000-47-25

Customization is available upon request.