

QLA-20-3000-30-35

0.02~3GHz, 30dB, 3.5dB

Features:
 * Broad Band
 * Low Noise

Applications:
 * Wireless
 * Receiver
 * Laboratory Test
 * Radar

Electrical

Frequency:	0.02~3GHz
Power Gain:	30dB typ.
Gain Flatness:	±2.5dB typ.(Within any 60MHz bandwidth)
Output Power (P1dB):	+15dBm typ.
Noise Figure:	3.5dB typ.
Spurious:	-60dBc typ.
Harmonic:	-10dBc typ.
Input VSWR:	1.45 typ.
Output VSWR:	2 typ.
Voltage:	+15V DC
Impedance:	50Ω
Input Power:	-14dBm max.

Mechanical

Size*1:	59.3*34.3*20mm 2.335*1.35*0.787in
RF Connectors:	SMA Female

[1] Exclude connectors.

Environmental

Operating Temperature:	-10~+50°C
------------------------	-----------

Outline Drawings

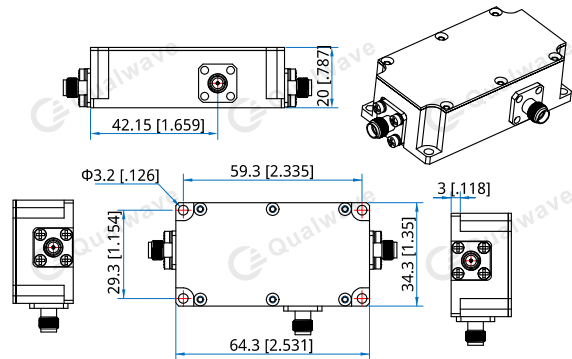

Unit: mm [in]

Tolerance: ±0.2mm [±0.008in]

How To Order

QLA-20-3000-30-35

Customization is available upon request.