

QLA-2000-10000-30-40

2~10GHz, 30dB, 4dB

Features:
 * Broad Band
 * Low Noise

Applications:
 * Wireless
 * Receiver
 * Laboratory Test
 * Radar

Electrical

Frequency:	2~10GHz
Gain:	30dB min.
Gain Flatness:	±1dB max.
Output Power (P1dB):	15dBm min.
Noise Figure:	4dB max..
Input VSWR:	2 max.
Output VSWR:	2 max.
Voltage:	+12V DC typ.
Current:	200mA max.
Impedance:	50Ω

Mechanical

Size*1:	40.208*27.762*9.703mm 1.583*1.093*0.382in
RF Connectors:	SMA Female
Mounting:	4-Φ2.464mm through-hole

[1] Exclude connectors.

Environmental

Operating Temperature:	-54~+70°C
Non-operating Temperature:	-55~+85°C

Outline Drawings

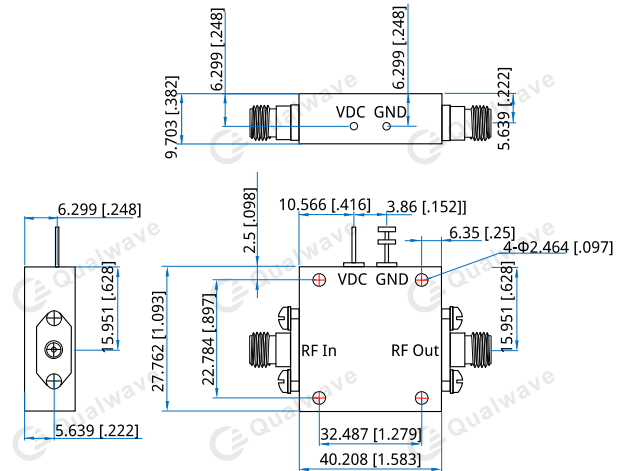

Unit: mm [in]

Tolerance: ±0.2mm [±0.008in]

How To Order

QLA-2000-10000-30-40

Customization is available upon request.