

QLA-500-18000-40-30

0.5~18GHz, 40dB, 3dB

Features:
 * Broad Band
 * Low Noise

Applications:
 * Wireless
 * Receiver
 * Laboratory Test
 * Radar

Electrical

Frequency:	0.5~18GHz
Small Signal Gain:	40dB min.
Gain Flatness:	±1.5dB typ.
Output Power (P1dB):	+10dBm min.
Noise Figure:	3dB max.
VSWR:	2.5 max.
Voltage:	+12V DC
Current:	200mA typ.
Impedance:	50Ω

Mechanical

Size ^{*1} :	40*35*12mm 1.575*1.378*0.472in
RF Connectors:	SMA Female
Mounting:	4-Φ2.2mm through-hole

[1] Exclude connectors.

Environmental

Operating Temperature:	-40~+70°C
Non-operating Temperature:	-55~+100°C

Outline Drawings

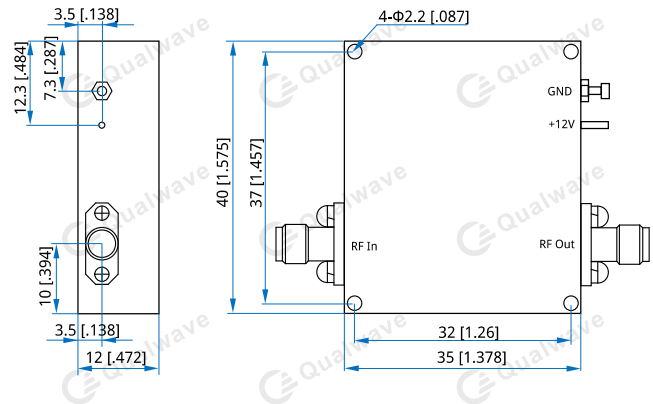

Unit: mm [in]

Tolerance: ±0.2mm [±0.008in]

How To Order

QLA-500-18000-40-30

Customization is available upon request.