

QLF-15000-50

DC~15GHz, 50dB

Features:

- * High Stopband Rejection
- * Small Size

Applications:

- * Telecom
- * Laboratory Test
- * Receivers
- * Instrumentation

Electrical

Frequency:	DC~15GHz
Insertion Loss:	1dB max. @DC~14.5GHz 2.5dB max. @14.5~15GHz
VSWR:	1.5 max.
Stop Band Attenuation:	50dB@16~22.3GHz min.
Average Power:	15W max.
Impedance:	50Ω

Mechanical

Size ^{*1} :	21*17*10mm 0.827*0.335*0.394in
RF Connectors:	SMA Female
Mounting:	3-Φ2.2mm through-hole

[1] Exclude connectors

Environmental

Operating Temperature:	-55~+85°C
------------------------	-----------

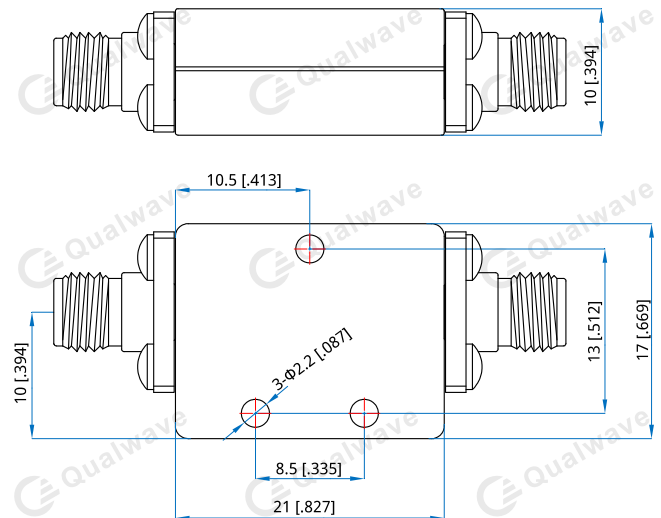
Outline Drawings

Unit: mm [in]

Tolerance: ±0.2mm [±0.008in]

How To Order

QLF-15000-50

Customization is available upon request.