

QMPS20

20°/GHz

Features:

- * Low Insertion Loss
- * High Power
- * High Reliable

Applications:

- * Laboratory Test
- * Transmitter
- * Instrumentation
- * Wireless

Electrical

Frequency:	DC~18GHz
Impedance:	50Ω
Average Power:	50W
Peak Power* ¹ :	5KW

[1] Pulse width: 5us, duty cycle: 1%.

Frequency (GHz)	VSWR (max.)	Insertion Loss (dB, max.)	Phase Adjustment* ² (°)
DC~2	1.25	0.35	0~40
DC~3	1.3	0.5	0~60
DC~6	1.4	0.75	0~120
DC~9	1.5	1	0~180
DC~12	1.6	1.25	0~240
DC~18	1.6	1.5	0~360

[2] Phase shift varies linearly corresponding to the frequency. For example, if the maximum phase shift is 360°@18GHz, the maximum phase shift is 180°@9GHz.

Mechanical

Size:	70*13*15mm 2.756*0.512*0.591in
Weight:	50g
RF Connectors:	SMA
Outer Conductor:	Gold plated brass
Male Inner Conductor:	Gold plated brass
Female Inner Conductor:	Gold plated beryllium copper

Environmental

Operating Temperature:	-10~+50°C
Non-operating Temperature:	-40~+70°C

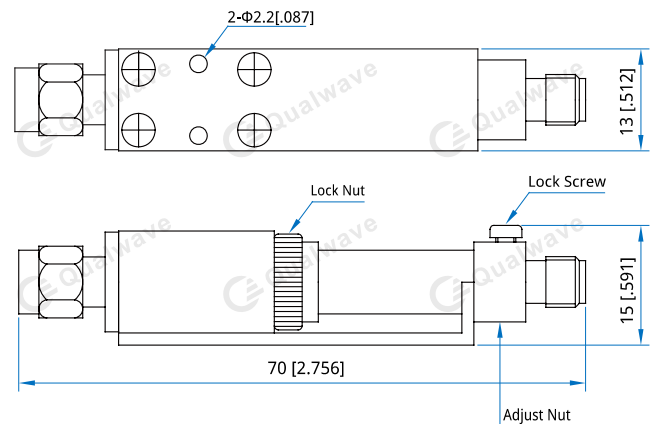
Outline Drawings

Unit: mm [in]

Tolerance: ±0.2mm [±0.008in]

Usage

1. Tighten the lock nuts.
2. Connect both ends to cables.
3. Release the lock nuts.
4. Turn the adjust nut to adjust phase.
5. Tighten the lock nuts.

How To Order
QMPS20-X-Y

X: Frequency in GHz

Y: Connector type

Connector naming rules:

S - SMA

Examples:

To order a phase shifter, DC~6GHz, SMA male to SMA female, specify QMPS20-6-S.

Customization is available upon request.