

QMPS900

900°/GHz

Features:

- * Low Insertion Loss
- * High Power
- * High Reliable

Applications:

- * Laboratory Test
- * Transmitter
- * Instrumentation
- * Wireless

Electrical

Frequency:	DC~1GHz
Impedance:	50Ω
Average Power:	100W
Peak Power*1:	5KW
VSWR:	1.5 max.
Insertion Loss:	2.5dB max.
Phase Adjustment:	0~900°

[1] Pulse width: 5us, duty cycle: 2%.

Mechanical

Size:	692*148*67.5mm 27.244*5.827*2.657in
Weight:	2700g
RF Connectors:	N Female, SMA Female
Outer Conductor:	Nickel Plated Brass
Inner Conductor:	Gold Plated Beryllium Bronze
Housing Material:	Aluminum

Environmental

Operating Temperature:	-10~+50°C
Non-operating Temperature:	-40~+70°C

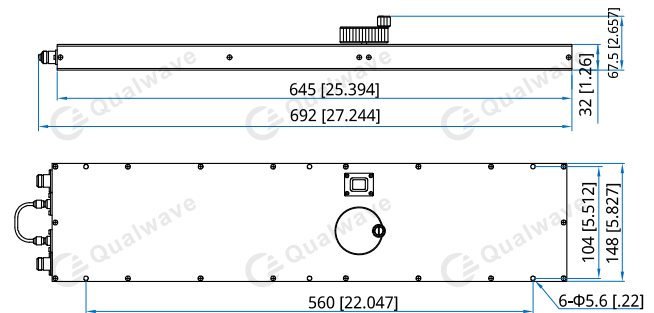
Outline Drawings

Analog

Unit: mm [in]

Tolerance: ±0.2mm [±0.008in]

How To Order
QMPS900-X-Y

X: Frequency in GHz

Y: Connector type

Z: Display

Examples:

To order an analog phase shifter, DC~1GHz, N female to N female, specify QMPS900-1-N-A.

Connector naming rules:

S - SMA

N - N

Display naming rules:

A - Analog

Customization is available upon request.