

## QWT19-K6 WR-19, 600W

Features:  
\* Low VSWR  
\* Broadband

Applications:  
\* Transmitters  
\* Antennas  
\* Laboratory Test  
\* Impedance Matching

### Electrical

Frequency: 39.2–59.6GHz  
VSWR: 1.2 max.  
Average Power: 600W

### Mechanical

Interface: WR-19  
Flange: FUGP500  
Material: Aluminum

### Outline Drawings

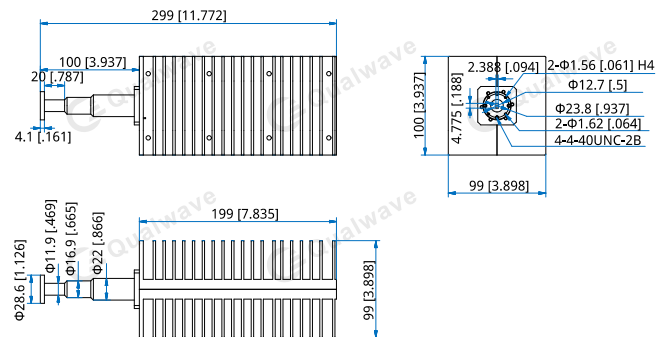

Unit: mm [in]

Tolerance:  $\pm 0.5\text{mm}$  [ $\pm 0.02\text{in}$ ]

### How To Order

**QWT19-K6**

Customization is available upon request.