

QPAS-8000-12000-40-47S

8~12GHz, 40dB, 47dBm

Features:

- * Small Size
- * Low Power Consumption

Applications:

- * Wireless
- * Transmitter
- * Laboratory Test

Electrical

Frequency:	8~12GHz
Gain:	40dB min.
Gain Control (Optional):	0~20dB, 1dB step
Gain Flatness:	±2.0dB typ.
Output Power (Psat):	47dBm min.
Harmonic:	-15dBc typ.
Spurious:	-60dBc max.
Input VSWR:	1.5 typ.
Output VSWR:	2.0 typ.
Voltage:	220V AC
Input Power Without Damage:	15 dBm max.
Protection:	Turn off automatically on temperature, voltage, current and VSWR exception.
Control interface(Optional):	LAN or RS422/RS232 or USB
Display:	LCD
Status:	Temperature, ON/OFF, Voltage, Current.

Mechanical

Size:	481.8*500*88.5mm 18.969*19.685*3.484in
Weight:	20kg max
RF Connectors:	SMA Female, N Female
Cooling:	Forced Air

Environmental

Operating Temperature:	-10~+50°C
Non-operating Temperature:	-30~+85°C

How To Order

[QPAS-8000-12000-40-47S](#)

Customization is available upon request.

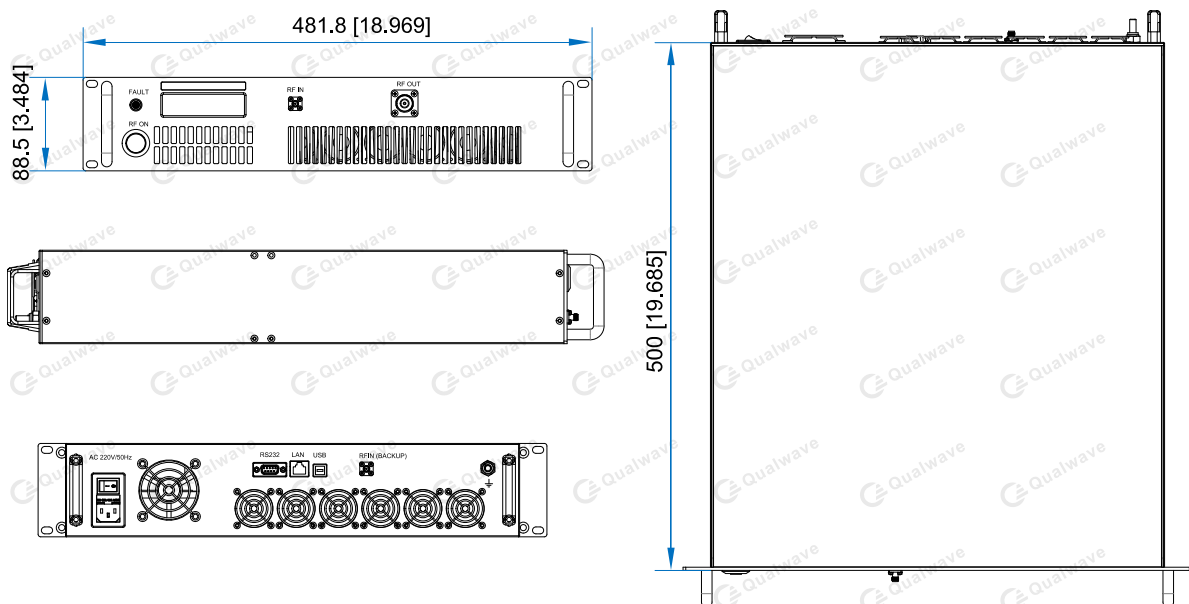
Outline Drawings

Unit: mm [in]

Tolerance: ±0.2mm [±0.008in]