

QPA-925-960-42-48S

925~960MHz, 42dB, 48dBm

Features:
 * Small Size
 * Low Power Consumption

Applications:
 * Wireless
 * Transmitter
 * Laboratory Test

Electrical

Frequency:	925~960MHz
Power Gain:	42dB min.
Gain Flatness:	±2dB typ.
Output Power (Psat):	48dBm min.
Spurious:	-60dBc typ. @DC~6GHz@Pout=48dBm
2 th Harmonic:	-35dBc typ. @Pout=48dBm
Input VSWR:	2 max.
Output VSWR:	2 max.
Voltage:	+32V DC max.
Input Power:	+10dBm max.
Other:	Built-in isolators have no impairment of full phase reflections
Temperature Check:	Vout=0.5V+(0.01V/°C)
Forward Power Check:	0.05V/dB
Reverse Power Check:	0.05V/dB
Power Amplifier Enabled:	TTL level, low active

Mechanical

Size*1:	198*88*35.7mm 7.795*3.465*1.406in
RF In Connectors:	SMA Female
RF Out Connectors:	N Female
Power Supply Interface:	Feed through
Mounting:	6-Φ3.2mm through-hole
Cooling:	Natural Cooling

[1] Exclude connectors.

Environmental

Operating Temperature:	-10~+50°C
------------------------	-----------

Outline Drawings

(The picture is for reference only, subject to the actual picture)

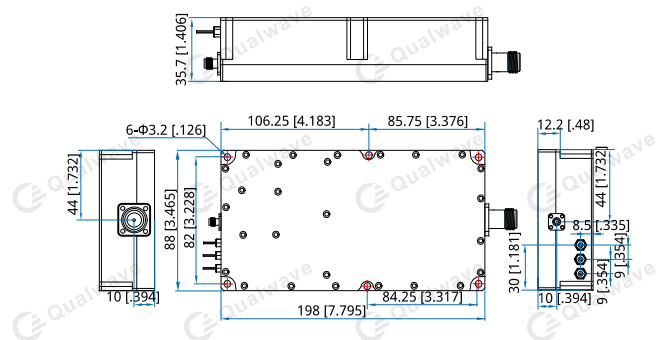

Unit: mm [in]
 Tolerance: ±0.2mm [±0.008in]

How To Order

QPA-925-960-42-48S

Customization is available upon request.