

QRHA284

2.6~3.95GHz, WR-284

Features:
* Broadband

Applications:
* Wireless
* Transceiver
* Laboratory Test
* Broadcast

Electrical

Frequency: 2.6~3.95GHz
Gain: 10, 15, 20dB
VSWR: 1.2 max. (Outline A, B, C)
1.4 max.

Mechanical

Interface: WR-284 (BJ32)
Flange: FDP32
Material: Aluminium

Environmental

Temperature: -55~+165°C

Outline Drawings

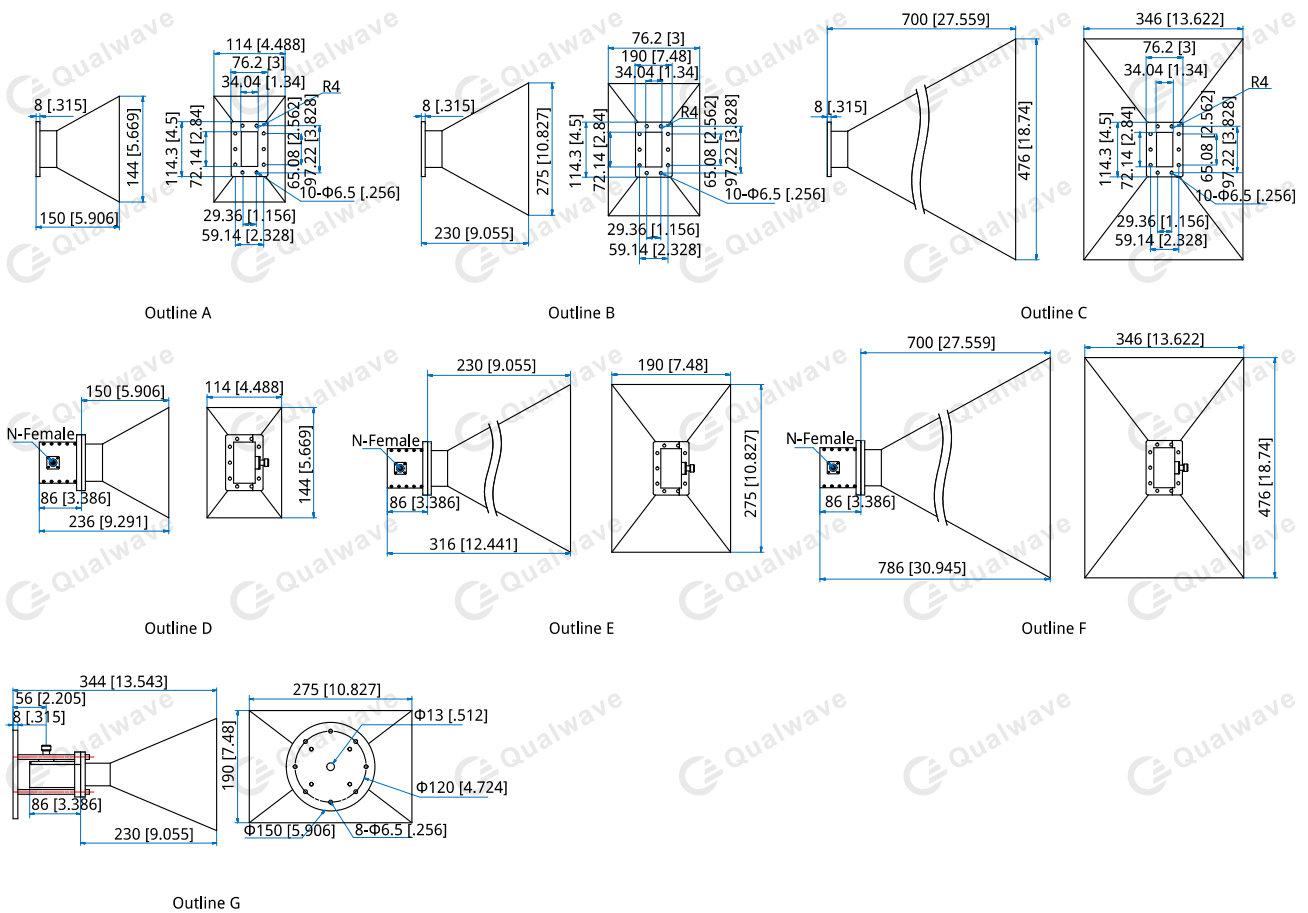

Unit: mm [in]

Tolerance: ±0.5mm [±0.02in]

Standard Gain Horn Antennas

How To Order

QRHA284-X-Y-Z

X: Gain in dB

10dB - Outline A, D

15dB - Outline B, E, G

20dB - Outline C, F

Y: Connector type if applicable

Z: Installation method if applicable

Connector naming rules:

N - N Female (Outline D, E, F, G)

S - SMA Female

Pannel Mount naming rules:

P - Pannel Mount (Outline G)

Examples:

To order an antenna, 2.6-3.95GHz, 15dB, WR-284, N female, Pannel Mount, specify QRHA284-15-N-P.

Customization is available upon request.