

QWCA-75-S WR-75 to SMA

Features:
* Low VSWR

Applications:
* Wireless
* Transmitter
* Laboratory Test
* Radar

Electrical

Frequency: 9.84~15GHz
VSWR: 1.2 max.
Insertion loss: 0.3dB max. (Outline C)

Mechanical

Coax Connectors: SMA
Waveguide Size: WR-75
Flange: FBP120/FBM120
Material: Aluminium
Finish: Conductive oxidation
Coating: Black paint
Ash paint (Outline B)

Environmental

Operating Temperature: -70~+165°C

How To Order

QWCA-75-X-Y-Z

X : Connector type.

Y : Configuration type.

Z : Flange type if applicable

Connector naming rules:

S - S Male (Outline A, Outline B, Outline C)

SF - S Female (Outline A, Outline B, Outline C)

Configuration naming rules:

E - End launch (Outline B)

R - Right angle (Outline A, Outline C)

Flange naming rules:

1 - FBP (Outline A, Outline B)

2 - FDP

3 - FBM (Outline C)

4 - FDM

Examples:

To order a waveguide to coax adapter, WR-75 to SMA female, right angle, FBP, specify QWCA-75-SF-R-1.

Customization is available upon request.

Outline Drawings

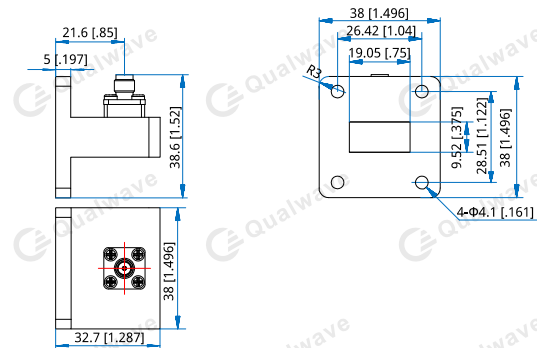

Outline A

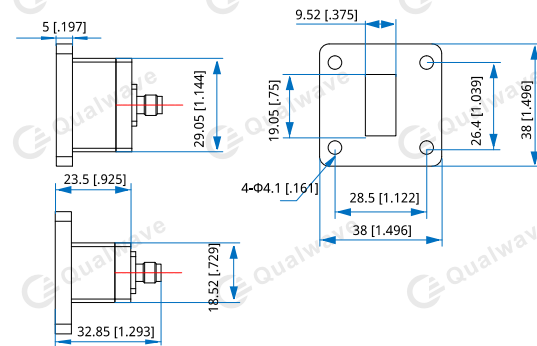

Outline B

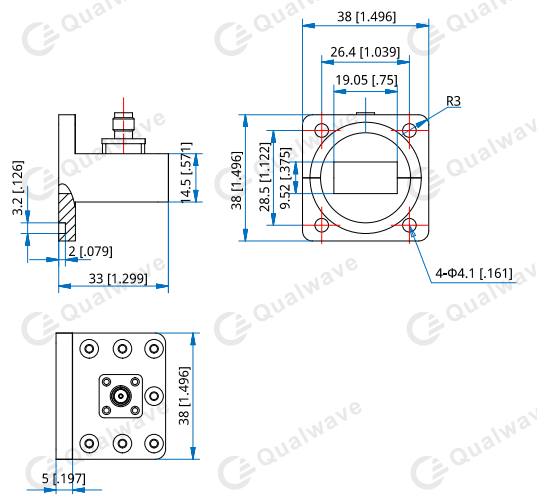

Outline C

Unit: mm [in]

Tolerance: ±0.2mm [±0.008in]